

Three-terminal positive voltage regulator

FEATURES

- Maximum output current IOM: 0.5A
- Output voltage VO: 6V
- Continuous total dissipation
PD: 1.5W (T_a = 25 °C)

MECHANICAL DAT

- Case: TO-220L Plastic Package
- Polarity: Color band denotes cathode end
- Mounting Position: Any

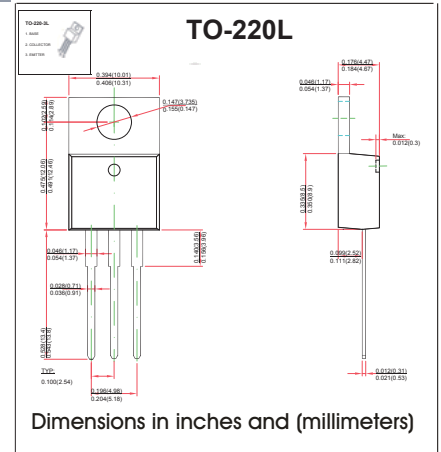

MAXIMUM RATINGS AND CHARACTERISTICS

@ 25°C Ambient Temperature (unless otherwise noted)

Parameter	Symbol	Value	Unit
Input Voltage	V _i	35	V
Thermal Resistance from Junction to Ambient	R _{θJA}	66.7	°C/W
Operating Junction Temperature Range	T _{OPR}	-25~+125	°C
Storage Temperature Range	T _{STG}	-65~+150	°C

ELECTRICAL CHARACTERISTICS AT SPECIFIED VIRTUAL JUNCTION TEMPERATURE

(V_i=11V, I_O=350mA, C_i=0.33μF, C_o=0.1μF, unless otherwise specified)

Parameter	Symbol	Test conditions	Min	Typ	Max	Unit
Output Voltage	V _o	25°C	5.75	6	6.25	V
		8V ≤ V _i ≤ 21V, I _o = 5mA-350mA	-25-125°C	5.7	6	6.3
Load Regulation	ΔV _o	I _o = 5mA-0.5A	25°C	18	120	mV
		I _o = 5mA-200mA	25°C	10	60	mV
Line Regulation	ΔV _o	8V ≤ V _i ≤ 25V, I _o = 200mA	25°C	5	100	mV
		9V ≤ V _i ≤ 25V, I _o = 200mA	25°C	1.5	50	mV
Quiescent Current	I _q	25°C		4.3	6	mA
Quiescent Current Change	ΔI _q	9V ≤ V _i ≤ 25V, I _o = 200mA	-25-125°C		0.8	mA
	ΔI _q	5mA ≤ I _o ≤ 350mA	-25-125°C		0.5	mA
Output Noise Voltage	V _N	10Hz ≤ f ≤ 100KHz	25°C	45		μV/V _o
Ripple Rejection	RR	9V ≤ V _i ≤ 19V, f = 120Hz, I _o = 300mA	-25-125°C	59	80	dB
Dropout Voltage	V _d	I _o = 350mA	25°C	2		V
Short Circuit Current	I _{sc}	V _i = 11V	25°C	270		mA
Peak Current	I _{pk}		25°C	0.5		A

* Pulse test.

TYPICAL APPLICATION

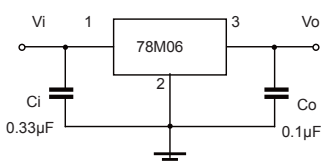

Note: Bypass capacitors are recommended for optimum stability and transient response and should be located as close as possible to the regulators.

RATINGS AND CHARACTERISTIC CURVES

TYPICAL APPLICATION

